

## Specification

Model	TR-PM602
Material	Alluminium alloy ADC12
Dimensions	Ø118 mm x 236 mm
Gross weight	602 g
Net weight	585 g
Working temperature	-40°C ... +70°C
Working humidity level	<90% (RH)
Colour	White

## Dimensions

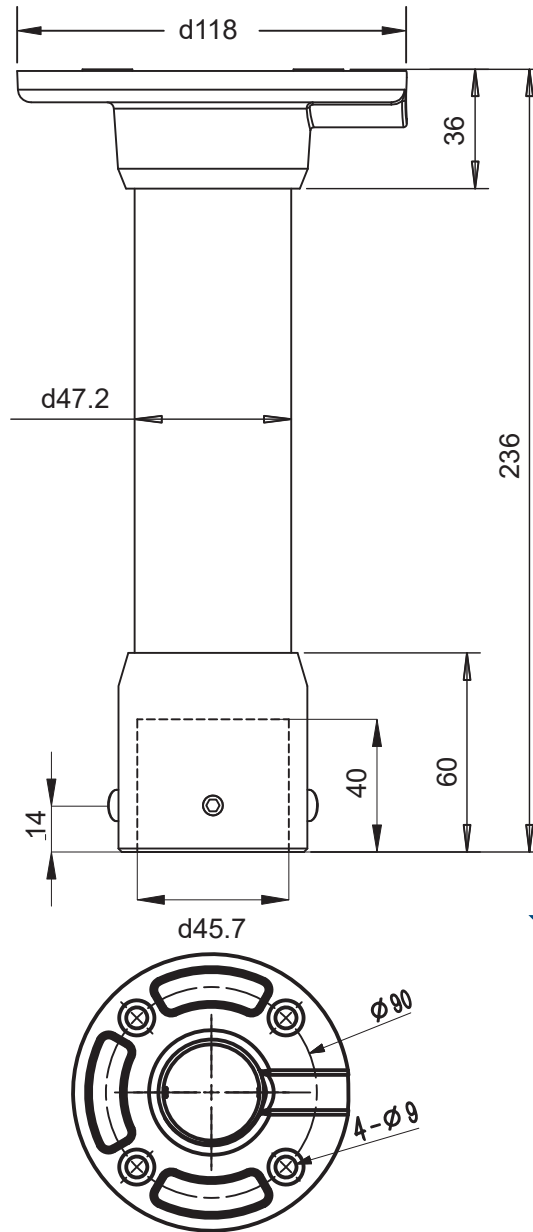

## TR-PM602

Pendant mount adapter

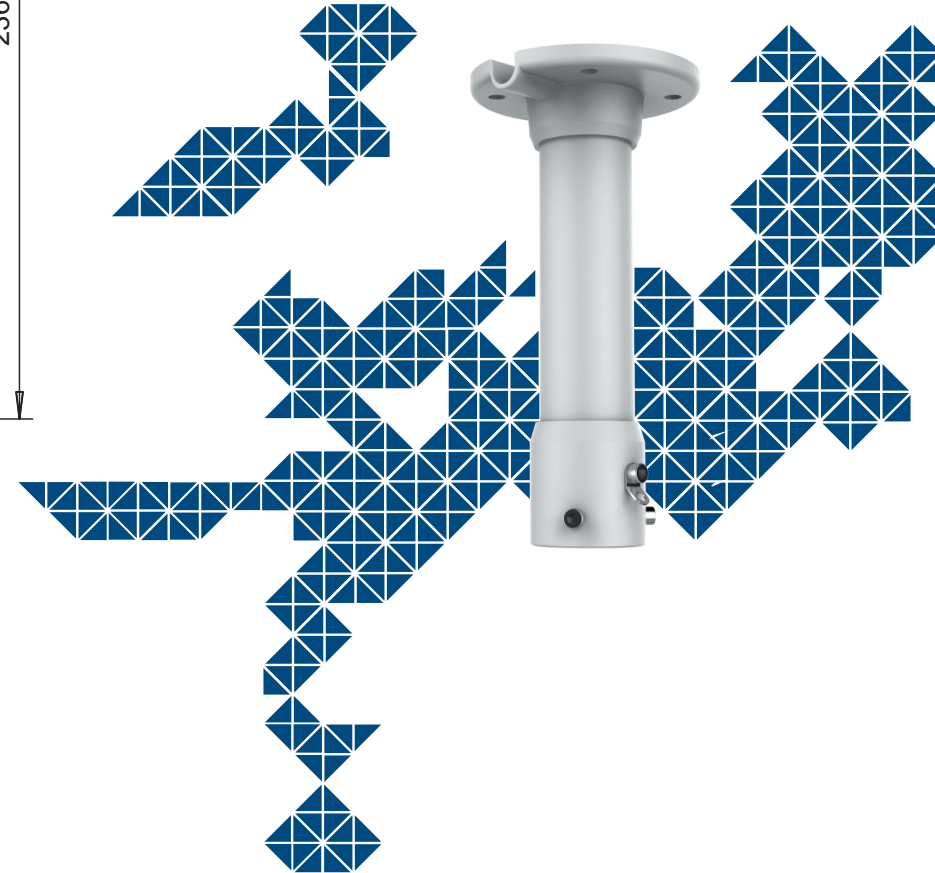

## Basic equipment

Pendant mount adapter	1 pcs.
Mounting kit	1 pcs.
Datasheet	1 pcs.