

# SBTL7200 Series

## Dual-Lane Swing Barrier Turnstiles

**SBTL7200** Dual-Lane swing barrier turnstile

**SBTL7211** Dual-Lane swing barrier turnstile  
(w/ a controller and RFID readers)

**SBTL7222** Dual-Lane swing barrier turnstile  
(w/ a controller and fingerprint & RFID readers)

**SBTL7233** Dual-Lane swing barrier turnstile  
(w/ Visible Light Facial Recognition devices)



SBTL7200 is a dual-lane swing barrier designed and served as an additional lane besides SBTL7000 to meet specific client requirements. It is designed for smooth and silent operation and draws very little power. With a compact design, the width of the cabinet is only 15 centimeters.

SBTL7200 barriers are usually held in locked status, thus denying access to the secured side. Upon the SBTL7200's reader (RFID and/or fingerprint verification) positively recognizing a user's valid access card or fingerprint, its barriers swing automatically, thus allowing users passage to the secured side.

During a power outage, the user can push through the barrier easily to exit to safety. SBTL7200 provides both security and convenient space, all in a very durable and elegant compact design.

## Features

### Reliability

- Painted steel casework ensures long-lasting durability.
- High-quality brushless motor.
- Simplify structure and connection, easy to maintain.

### Safety Features

- Barriers unlock automatically during a power outage.
- All smooth finish. No exposed screws.
- The ergonomic design makes card and fingerprint authentication fast & simple for users.

### Built-in Reader Integration

- SBTL7200 series ships already integrated with our customers' preference for either card or fingerprint access control reader. This greatly reduces installation time & expense.
- SBTL7200 series and associated access control readers are all factory-tested prior to shipping.
- ZKTeco provides true plug & play turnstiles with the lowest possible total cost of ownership in the industry.

## Specifications

Power Requirements	AC 110V/220V, 50/60Hz
Working Temperature	-20°C to 70°C
Working Humidity	5% to 95%
Running Power	30W
Infrared Sensor	6 pairs (Optional: 10 pairs)
Working Environment	Indoor/Outdoor (if shelter available)
Max. Speed of Throughput	30 people per minute
Lane Width (mm)	660 (Optional: 900)
Dimensions (L*W*H)	1200 * 150 * 1028 (mm)
Dimensions with Packing (L*W*H)	1290 * 330 * 1184 (mm)
Weight	72kg
Weight with Packing	92kg
LED Indicator	Support
Cabinet Material	Cold rolled sheet
Lid Material	Cold rolled sheet
Surface Finishing	Powder coating
Barrier Material	Acrylic
Barrier Movement	Swing
Emergency Mode	Support
Security Level	Medium
MCBF	5 million
Opening Time	0.8s
Opening Noise	≤30dB

## Dimensions (mm)

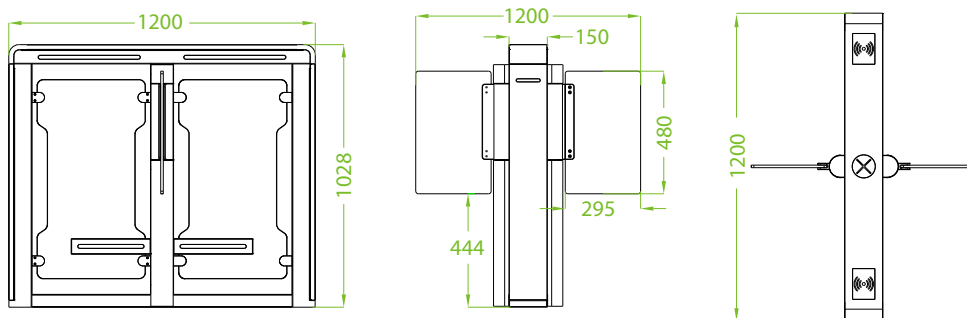

## Typical Application

