

# User Manual

## COLOR VIDEO SLAVE PHONE CAV-70MGX+











- Thank you for purchasing COMMAX products.
- Please carefully read this User's Guide (in particular, precautions for safety) before using a product and follow instructions to use a product exactly.
- The company is not responsible for any safety accidents caused by abnormal operation of the product.

# Index

1.Introduction	4
1.1. Product component	4
1.2. Screen composition	4
1.3. Wireless network connection	5
1.4. Sign up	6
1.5. Using Smartphone	7
2.Home screen	9
2.1. Screen composition	9
2.2. Edit space background	10
2.3. Place/Delete device icon on home screen	10
2.4. Place/Delete widget on home screen	11
2.5. IoT Device connection	11
2.6. Place/Delete apps on home screen	11
3.Call	12
3.1. Entrance Call	13
3.2. Guard Call	14
3.3. Call log	15
3.4. Receive a call via Smartphone	15
4.Security	16
4.1. Emergency	16
4.2. CCTV	17
4.3. Emergency record	18
4.4. Emergency test	18
5.Control	20
5.1. Lighting control	20
5.2. Checking multi-sensor	20
5.3. Magnetic sensor monitoring	21
5.4. Adding devices	21
5.5. Edit device	22
6.Scenario/schedule setting	23
7.Convenient function	29
7.1. Calculator	29
8.Setting	30
8.1. Environment set up	30
8.2. Password change	30
8.3. Receive a call via Smartphone	31
8.4. Firmware update	31
8.5. Connect to COMMAX	31
8.6. General setting	32
8.7. Wireless network connection	32
8.8. Screen setting	33
8.9. Language and key setting	33
8.10. Date and time setting	34
8.11. System information	35
9.Appendix	36
9.1. Wireless device Registration/Disconnection	36
9.2. Installation	43
9.3. Wiring Diagram and Components	44
10.pecification	46

# Warnings and caution

Please follow the things described below in order to prevent any danger or property damage.

	<p><b>Warning</b> It may cause a serious damage or injury if violated.</p>		<p>Prohibition.</p>
	<p><b>Caution</b> It may cause a minor damage or injury if violated.</p>		<p>No disassembly</p>
			<p>No touch</p>
			<p>Must follow strictly.</p>
			<p>Shows plugging out the power cord without an exception</p>
			<p>Shows the warning and caution for an electric shock.</p>
			<p>Shows the warning and caution for a fire.</p>

## Warning

**Power & Installation**

Please don't use several products at the same time on one power socket.

- It may cause a fire due to an abnormal overheating.

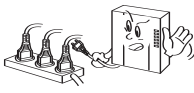



Prohibition 

Please don't bend the power cable excessively or it may cause an electric shock.

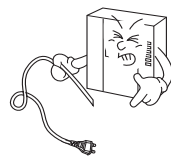
- fire when using a damaged power cable.



Prohibition  

Please don't handle the power cable with a wet hand.

- It may cause an electric shock.

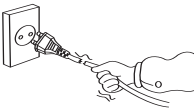

Prohibition 

Please plug out the power cable from the socket when not using it for a long period of time.

- It may shorten the product lifespan or cause a fire.





Request 

Please don't install the product in the place where there is much oil, smoke or humidity.

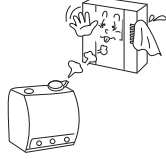
- It may cause an electric shock or fire.





Prohibition  

Please don't install the product with the lightning and thunder.

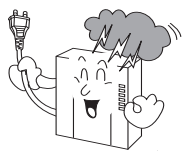
- It may cause an electric shock or fire.



Prohibition  

Please don't use and connect this product with other products with different rated voltage.

- It may cause a disorder or fire.



Prohibition 

When installing the product that generates heat, please install the product away from the wall (10cm) for the ventilation.

- It may cause a fire due to the increased internal temperature.

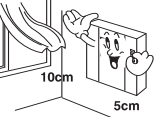

Prohibition 

## ⚠ Warning

### Cleaning & Use

Please don't disassemble, repair or rebuild this product arbitrarily (please contact the service center if a repair is needed).

- It may cause an electric shock or fire.

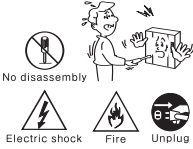

If an abnormal sound, burning smell or smoke is coming out of the product, please plug out the power cable and contact a service center.

- It may cause an electric shock or fire.

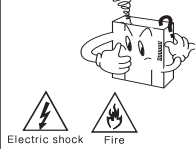

Please don't insert any metallic or burnable materials into the ventilation hole.

- It may cause an electric shock or fire.

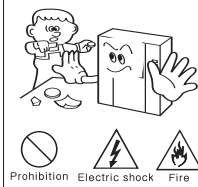

Please use only the designated batteries for the products of using DC power.

- It may cause an electric shock or fire.

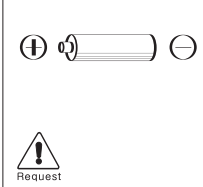

## ⚠ Caution

### Power & Installation

Please plug the power cable firmly into the inner end.

- It may cause a fire.

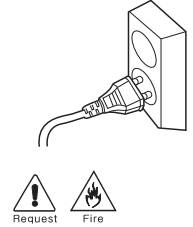

Please hold the plug tightly when unplugging the power cable (a part of the copper wire may be disconnected if the grabbing is only made on the cord when pulling out the cable).

- It may cause an electric shock or fire.

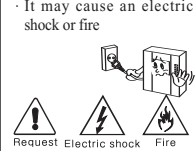

When connecting the power cables after cutting the cable, please install the product with power off.

- It may cause an electric shock or fire.

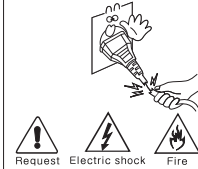

When installing the product, please fix it firmly while using the wall-mounting unit and screws.

- It may cause an injury from the falling object.

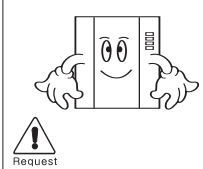

Please be careful when using an AC circuit breaker since there is a possibility of an electric shock.

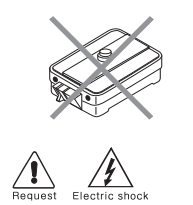

Please check the use voltage and current for the DC-only products and use the appropriate rectifier.

- It may cause a fire.

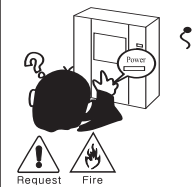

Please avoid direct rays of the sun or heating devices at a time of installation.

- It may cause a fire.

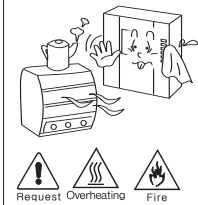

Please don't install the product on an unstable place or small support board.

- It may cause an injury if it falls down while in use.

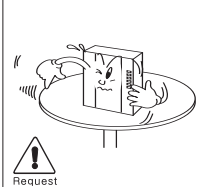

### Cleaning & Use

When cleaning the product, please rub it with a soft and dry cloth after plugging out the power cable. (Please don't use any chemical products such as wax, benzene, alcohol or cleanser.)



Please don't drop the product on the ground and don't apply a shock.

- It may cause a failure.

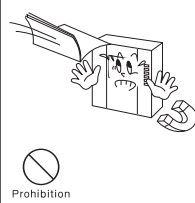

Please use the designated connection cable within the maximum calling distance designated for the product.

- It may reduce the product performance.

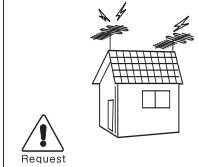

# 1. Introduction

## 1.1. Product component

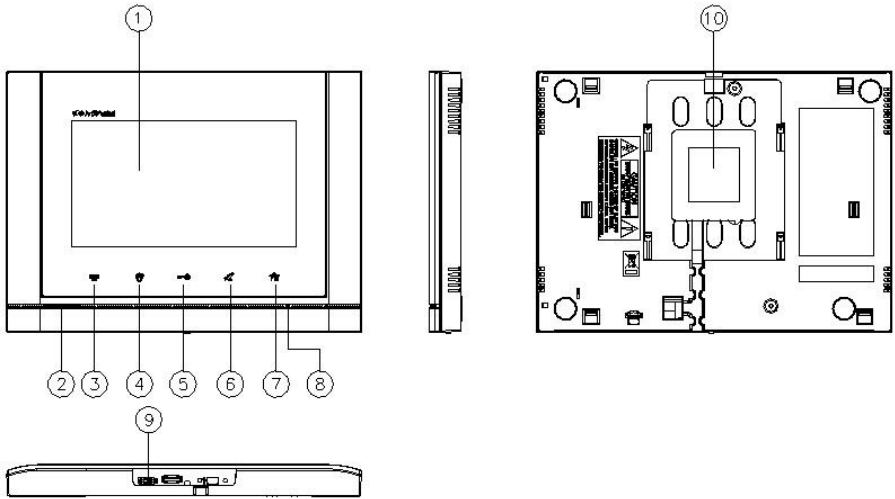

- ① TFT LCD Monitor
- ② Speaker
- ③ Emergency button
- ④ Guard button
- ⑤ Door open button

- ⑥ Call button
- ⑦ Home button
- ⑧ Microphone
- ⑨ Power switch
- ⑩ Connection terminal

## 1.2. Screen composition

### The bottom button of home screen



## 1.3. Wireless network connection

Press the 'Setting' button for setting screen.

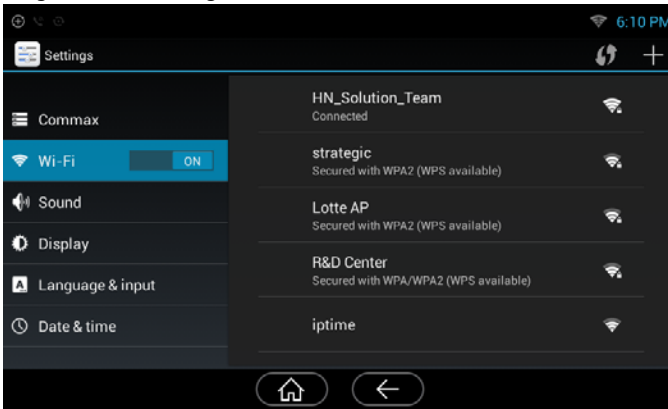

### Wi-Fi On/Off

Setting → Wi-Fi

Click the check box to turn on or off Wi-Fi.

### Wi-Fi Connection

Setting → Wi-Fi setting

You can search surrounding network and connect to selected wireless network.

Select the Wi-Fi from the network list of auto-discovered and enter the password to connect network if necessary. If protected Wi-Fi with lock, the password need to be entered to use the Wi-Fi.

### Add Wi-Fi directly

When the Wi-Fi you want is not discovered, you can add it entering the Wi-Fi information directly to the list.

Select "Add Wi-Fi network" at the bottom of Wi-Fi list.

Enter SSID of network, select security type, enter the password and select EAP way. The different information is shown according to the security type.

### Disconnect Wi-Fi

Not to connect the previous Wi-Fi automatically, initialize registered network information. First, select connected Wi-Fi and select Don't save. Then, the Wi-Fi will be disconnected and the previous connect information is initialized.

## 1.4. Sign up



Sign up

### Sign up

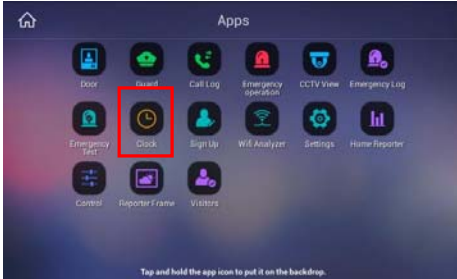

1) Select 'Sign up' button.



- 2) Enter 'ID' and select 'Duplication check' button.
- 3) Select your country.
- 4) Enter 'Password' and 'Retype Password' and select 'Registration' button.

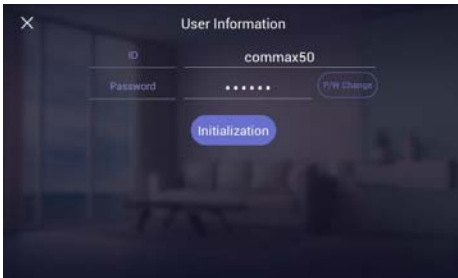

5) Your sign up is completed.

### Edit, Initialize

- 1) If your ID is registered, your information will be shown. To change the password, select 'P/W Change' button..
- 2) If you want to delete your ID, select 'Initialization' button.

※f To receive a call and control the device via Smartphone app, Sign up is necessary.

※f To sign up, the internet access is necessary.

## 1.5. Using Smartphone Access Smartphone

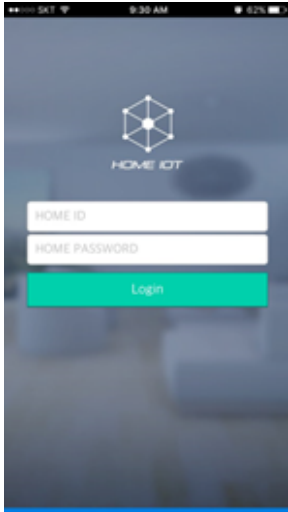

- 1) Run 'IP Home IoT' app.
- 2) Enter 'ID' and 'Password' and press 'Login' button.



- 3) Click 'Call' button to make a call.
- 4) When you click 'Refuse' button, the call is disconnected.



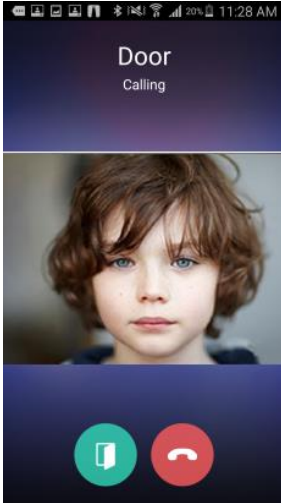

5) When the call is connected, the entrance screen is shown.

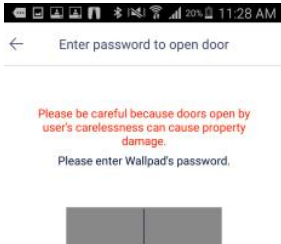





- 6) If you press 'Open Door' button, a warning message will be displayed. If you click 'Cancel' button, the popup window will close.
- 7) Enter the password registered in wall pad and press 'OK' button to open the door.

## 2. Home screen

### 2.1. Screen composition



 <p>Entrance</p>	Entrance monitoring, Visitor communication
 <p>Call log</p>	To check Call log
 <p>Emergency</p>	Home emergency button
 <p>APPs</p>	All installed apps list

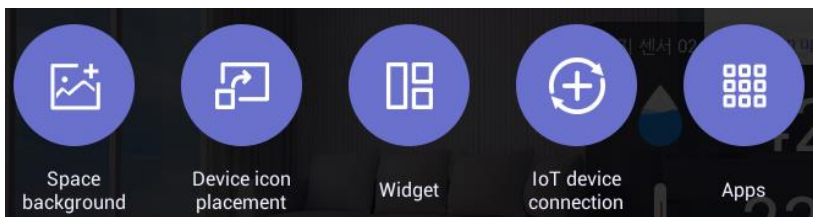

※f If you press and hold the home screen for about 1 second, you will get a menu that allows you to perform "Edit space / Device layout / Add device / Widget layout / App layout".

## 2.2. Edit space background

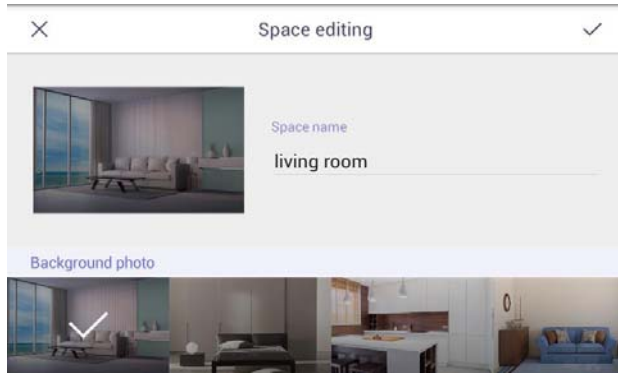

- 1) Press and hold the Home screen for about a second.
- 2) Click the 'Space Background' button.
- 3) Select the background picture to use.
- 4) Enter a space name.
- 5) Press 'OK' button to save the background. Press 'Close' button to cancel editing.

## 2.3. Place/Delete device icon on home screen

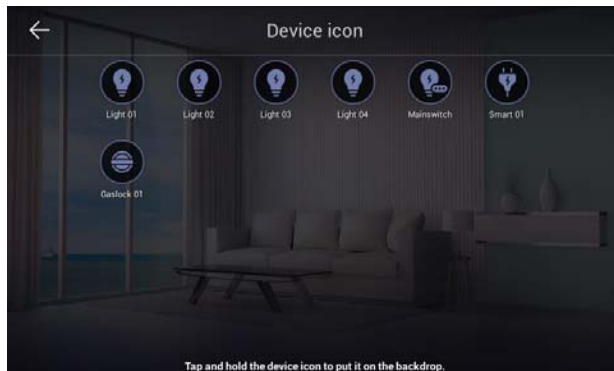

- 1) Press and hold the Home screen for about a second.
- 2) Click the 'Place icon' button.
- 3) You can place the device icon on the home screen by pressing and holding.
- 4) On the home screen, press and hold the icon to delete will be deleted when moved to the trash.

## 2.4. Place/Delete widget on home screen



- 1) Press and hold the Home screen for about a second.
- 2) Click the 'Widget' button.
- 3) Long press on the widget to place it on the home screen.
- 4) On the home screen, touch and hold the widget to delete will be deleted when moved to the trash

## 2.5. IoT Device connection

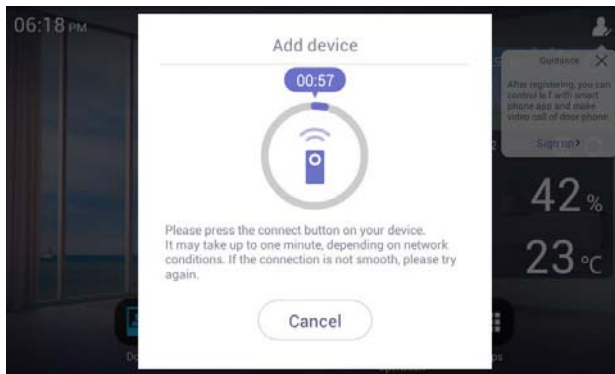

- 1) Press and hold the Home screen for about a second.
- 2) Click the 'IoT Device connection' button.
- 3) Connect each device according to the device pairing method. (It can be up to 60 seconds.)
- 4) Press the 'Cancel' button to cancel the pairing connection.
- 5) When the device is registered, the device is automatically placed on the home screen.

## 2.6. Place/Delete apps on home screen

- 1) Press and hold the Home screen for about a second
- 2) Click the 'Apps' button.
- 3) Tap and hold the icon of the app you want to place on the home screen.
- 4) On the home screen, touch and hold the icon of the app you want to delete to move it to the trash, and the app icon will be deleted.

### 3. Call

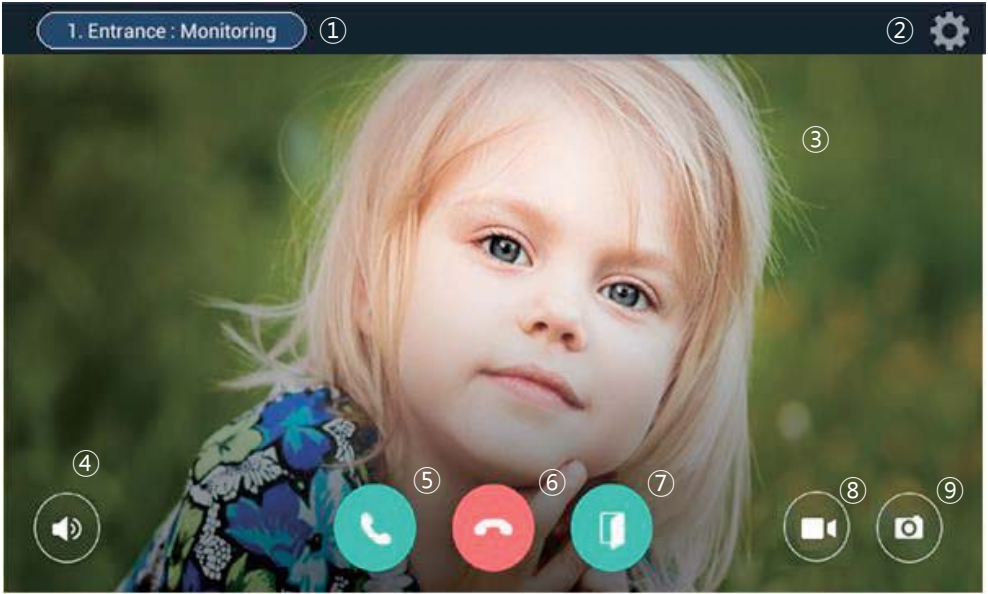

Call connection screen and call screen

- |                                       |                                |
|---------------------------------------|--------------------------------|
| ① Activation and waiting call display | ⑤ Receive a Call               |
| ② Setting the front door of our house | ⑥ Call rejection, cancellation |
| ③ Connection screen                   | ⑦ Open the door                |
| ④ Call volume and volume control      | ⑧ Store visitor video          |
|                                       | ⑨ Store visitor foto           |

※ Call reception screen differs depending on the type of door call, security call, etc.

## 3.1. Entrance Call



Monitoring of my house entrance

### Monitor and call my house entrance

- 1) You can monitor the entrance of our house by pressing the door icon or by pressing the 'door' button on the dial screen.
- 2) Press the "Cancel call" button to cancel monitoring.
- 3) If you want to talk during monitoring, press (call) button  .
- 4) Press the "End call" button.

### Common entrance monitoring and calling

- 1) Press the "door" icon.
- 2) Select the number of common porches to monitor.
- 3) 'Common entrance' button can be pressed to monitor the common entrance.
- 4) Press the "Cancel call" button to cancel monitoring.
- 5) If you want to talk during monitoring, press (call) button  .
- 6) Press the "End call" button.

### Open the door of my house

- 1) Press the 'Open Door' button during a call.
- 2) Open the door.







### Open common entrance door

- 1) Press the 'Open Door' button during a call.
- 2) Open the door.

### Saving the image of our house / common entrance visitor

- 1) Press the 'Record' button during a call or a call.
- 2) You will see a photo of the visitor on the home screen if it successfully saved.

## Setting my home screen



- 1) Press the 'entrance' button on the phone screen.
- 2) Press the 'Screen Settings' button.
- 3) On the Screen Settings tab, press the button  (Color),  (chroma),  (Brightness), or  (Contrast) you want to set and adjust the value with the  (Left) and  (Right) buttons.
- 4) Press  'Reset' button to change to initial screen .

※ The screen settings can be set only when monitoring the door.



[Setting my house entrance screen]

## Receive a call at our house / common entrance

- 1) Visitor screen are displayed on the wall pad with bell sound, when you receive a call.
- 2) Press the  (Talk) button to connect the call and press the  (Talk reject) button to reject the call.
- 3) Press  the (End Call) button to end a call

## 3.2. Guard Call



Call guard station

### Call guard station

- 1) Click on the 'guard room' icon to call the guard room.
- 2) Press the 'guard' button to call the guard..
- 3) Press the "End call" button, to end the call.

### Receive call from guard station

- 1) You will see a guard station with bell sound on the wall pad, when you receive a call.
- 2) Press the  (Talk) button to connect the call and press the (Talk reject) button to reject the call.
- 3) Press the (End Call) button to end a call

※ The call ends automatically, if you use the call transfer during a call

### 3.3. Call log



Call log  
Call Type  
Make a call



Call log screen

#### Use call logs

- 1) You can press  the button from the call log and connect the call .
- 2) You can clear the call history by clicking the trash button at the top of the screen and pressing the 'OK' button

### 3.4. Receive a call via Smartphone



Wall pad screen when Smartphone call is connected

- 1) The image of visitor displayed on screen with a ringing bell.
- 2) Press the "Call" button if you want to make a call and press the "Reject" button to reject.
- 3) Press 'Exit' to end the call..
- 4) The wall pad will be provided a message "the wireless device is calling" when you make a call connection with your Smartphone".



# 4. Security

## 4.1. Emergency



Emergency

Emergency detection

An emergency situation occurs when the emergency button is pressed. Emergency situation is proceeded in three steps (occurrence → stop → return).

### Emergency situation occurs

- 1) You can make an emergency by pressing the emergency icon or by pressing the emergency button on the front of the product. Emergency type is displayed at the top of the screen and a siren sound is generated

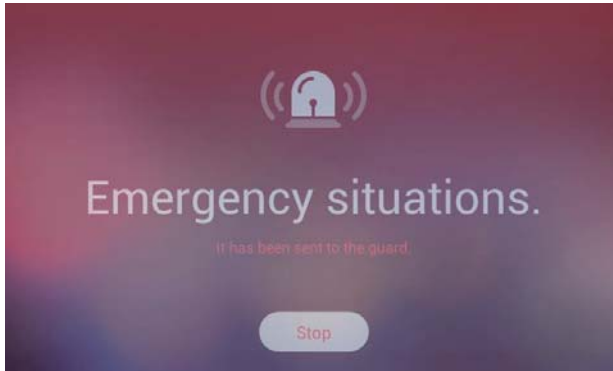

### Emergency stop

- 1) Press the 'Stop' button at the bottom of emergency alert screen.
- 2) Enter the password (initial password: 1234) when you see the password screen.

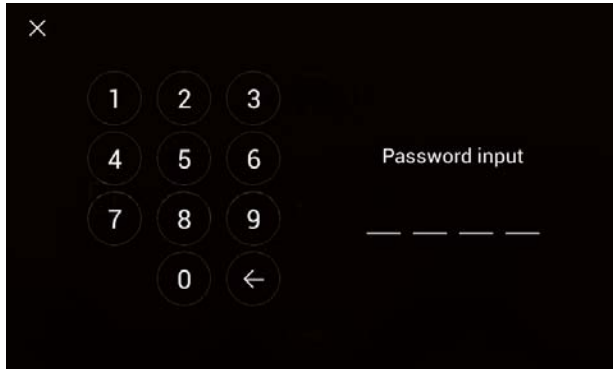

Password input

### Emergency Return

- 1) The button at the bottom of the screen changes to 'Return' if the password is matched.
- 2) Press the 'Return' button at the bottom of the screen.
- 3) Emergency situation is stopped, when the emergency returns.

## 4.2. CCTV



Checking CCTV video  
Save images



CCTV screen

① CCTV video screen	④ Channel list
② Save screen	⑤ Selection list
③ Select DVR	⑥ Checking the recorded image

### Viewing and saving CCTV images

- 1) Select the DVR (③) you want to watch and press the channel list (④) to display the connected CCTV list (⑤).
- 2) If you click on the desired CCTV list, it will be displayed on the CCTV video screen.
- 3) Press the 'Save' button to save the desired screen.
- 4) You can check the saved image by pressing the image view (⑥).

### 4.3. Emergency record



Emergency record

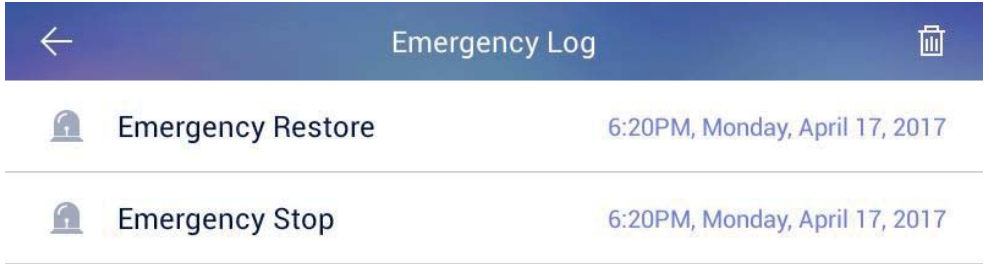

Emergency record screen

### Delete emergency records

- 1) You can delete emergency records by clicking the trash button at the top of the screen and then pressing the 'OK' button.

### 4.4. Emergency test



Fire emergency test  
Gas Emergency Test

You can test the emergency situation by pressing the emergency test button.

Emergency test situations will only occur on the wall pad and will not be notified to the smartphone and guard.

### Emergency test

- 1) You can make an emergency by pressing the emergency button (fire / gas emergency) you want to test.
- 2) Emergency type is displayed on the screen and a siren sound is generated.



## Test emergency screen

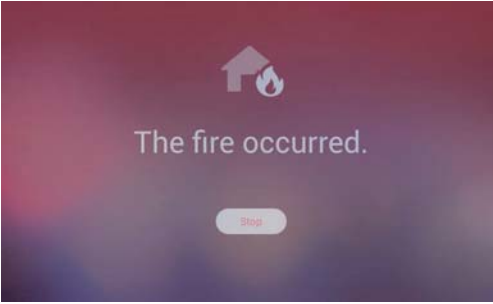

1) Fire emergency screen

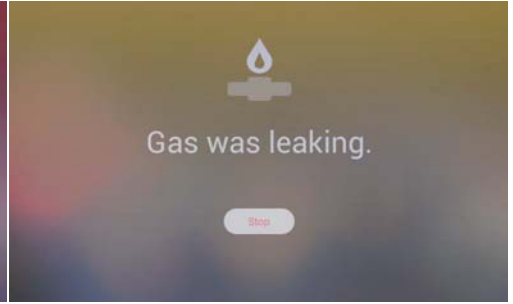

2) Gas emergency screen

## Test emergency stop

- 1) Press the 'Stop' button.
- 2) Emergency test is ended.

# 5. Control

## 5.1. Lighting control

- 1) Go to the Lighting tab.
- 2) When you press power button of whole lightings, all lightings are turned on.
- 3) When you press power button of whole lightings, all lightings are turned off.
- 4) Press the power button of the lighting you want to control to turn the light on or off.



[Lighting control screen]

## 5.2. Checking multi-sensor

- 1) Go to the Indoor Environment tab.
- 2) Displays information collected in indoor environment by multi-sensor.

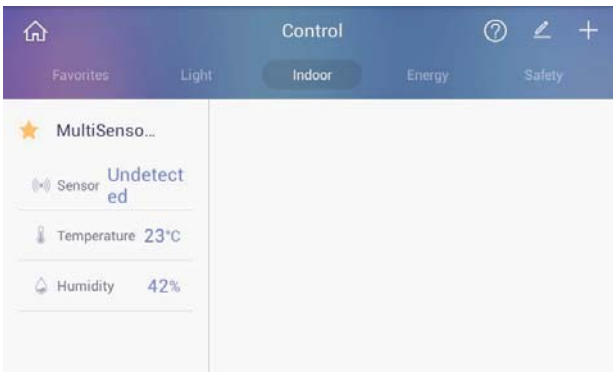

[Multi-sensor screen]

### 5.3. Magnetic sensor monitoring

- 1) Go to the Safety tab.
- 2) 'Detected' is displayed when door open is detected.
- 3) If no door open is detected, "No detected" is displayed.

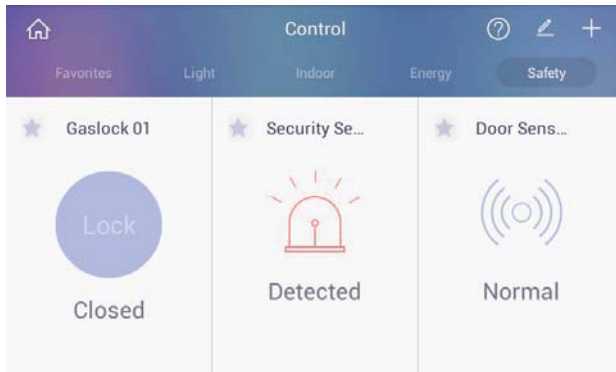

[Magnetic sensor screen]

### 5.4. Adding devices

- 1) Press the + button to enter the Add Device mode.
- 2) Pairing mode is for 1 minute.

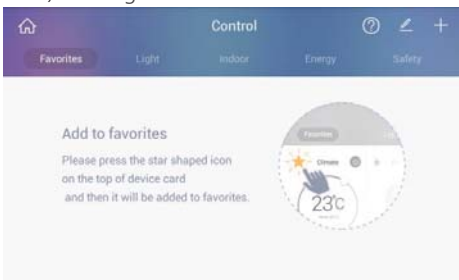

[Control screen]

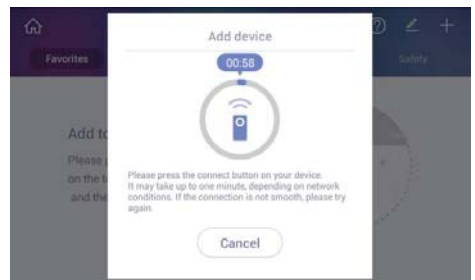

[Device addition screen]

## 5.5. Edit device

### Change the device nickname

- 1) Select the device and change the nickname.
- 2) Press 'OK' and then the name of device is changed.

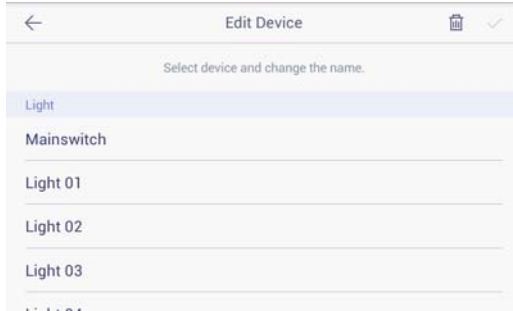

*[Device edit screen]*

### Remove device

- 1) Press the "Trash" button.
- 2) Select the device you want to delete.
- 3) Press the 'Finish' button to delete the device.

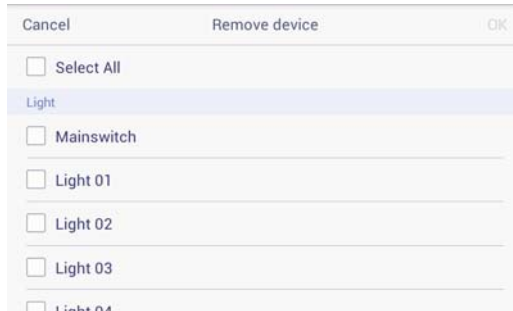

*[Remove device screen]*

## 6. Scenario/schedule setting

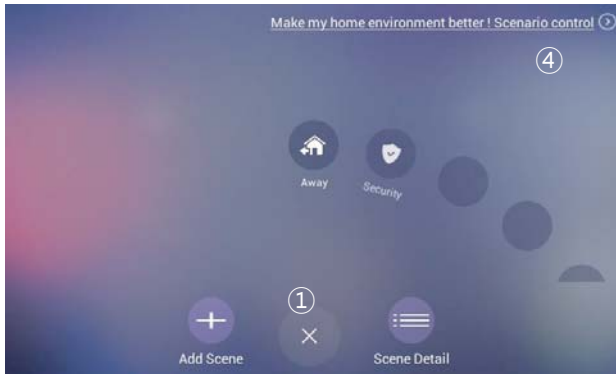

[Scenario/schedule control screen]

① Go to home screen	③ Scenario view detail
② Scenario addition	④ Go to scenario control

### 6.1. Scenario addition

- 1) Press "Add Scene" button on "Add Scene Main Screen."
- 2) The device selection dialogue window will be displayed, if you click 'Create scene '.
- 3) Select the device to set and press the OK button on the upper right corner.
- 4) Select the device attribute and set the device.
- 5) Click the 'Enter Name button' at the top of the screen and then set the name and icon.

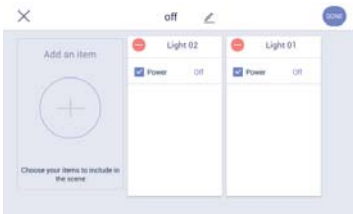

[Device attribute setting screen]

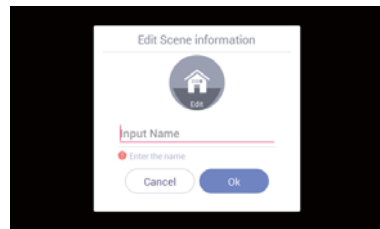

[Name and Icon setting screen]



## 6.2. Away mode



Away mode on/off

Away setting status display

When you go out, you can set security sensor, visitor video auto save etc.

### Running Away mode

- 1) Press the Away icon to set the away mode.
- 2) The away mode will be executed automatically after the specified away delay time.
- 3) Press the 'Close' button to cancel the away settings.



[Away mode screen]

① Away delay time	③ Start away mode
② Items to be run when out	

※ If you are setting the security mode, away settings will not be executed.

※ Away delay time is the time set by Away Setting → Option → Away Delay Time.

### Setting the away mode

- 1) Set items to be performed when going out.
- 2) Press the 'Option' button on the away setting screen to display the setting status.
- 3) Check the security sensor and execution item to use.
- 4) Click the OK button to save.

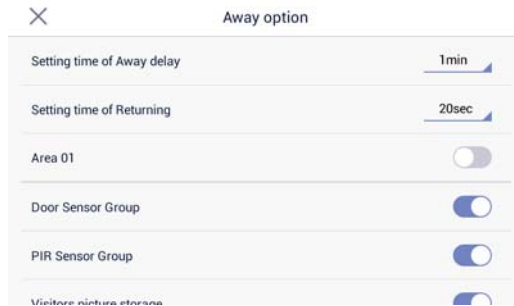

[Away mode setting screen]

### Turn off Away mode

- 1) On the Scene screen, press the Away setting button.
- 2) If password input screen is displayed, enter password and press 'OK' button.
- 3) When password is matched, Away mode is canceled.

## 6.3. Security mode



Security mode on/off

Security setting status display

- ※f This function is implemented when a security sensor is installed in a household.
- ※f Sensor usage setting can be set in [Setting> commax connection> Sensor use selection].

### Security mode setting

- 1) Check the security sensor to set by pressing the 'Security Zone (②)' button.
- 2) Press the 'Apply (①)' button to activate the security sensor in the designated zone.



[Security Setting Screen]

- ※ The number of images in the security setting sensor is displayed by the number of sensors set.

## Turn off security mode

- 1) Press the 'Security' button.
- 2) When the password input screen is displayed, enter the password and press 'OK'.
- 3) If the password matches, the security mode is canceled.

## 6.4. Scenario Control

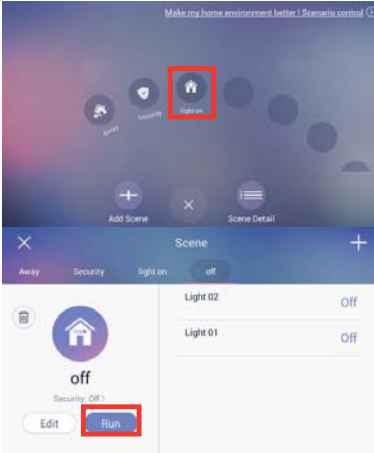

- 1) Click the scene you want to execute from the list.
- 2) The set device is controlled collectively.
- 3) Control Scenery / Scenario Press 'Detail View' button on the main screen.
- 4) Press 'Run' button to control the set devices in batch.

## 6.5. Scenario Edit



- 1) 'Press the 'Security: Apply>' button to enable or disable security for the scene.
- 2) Press the 'Edit' button to edit the scene.
- 3) You can add and edit device type, device attribute, scene name and icon on the edit screen.

## 6.6. Scenario Control setting (Mode)

You can perform the desired operation according to the conditions set by the scenario control.

예) Turn off the living room light when you go out

※ Depending on the server status, the control time may take from about 1 minute to a maximum of 5 minutes.

## 6.7. Adding Scenario Controls

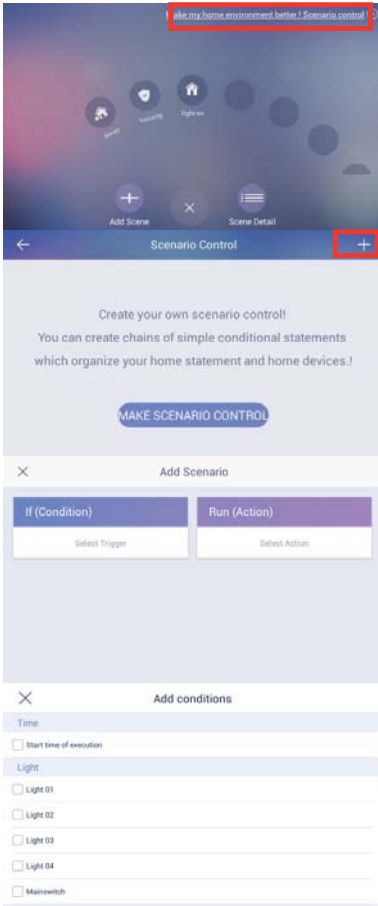

1) Click the 'Scenario Control' button on the top right.

2) Click the 'Create Scenario Control' button or the '+' button in the upper right corner.

3) Press the '+' button on the upper right of 'Condition'.

4) Select the device to be set.



- 5) Select the item of the selected device.
- 6) Press the "-" button on the upper right corner to save
- 7) Set 'Execution Item' setting 4)~ 6) as same as 'Condition'.



- 8) When the setting of "condition" and "execution item" is completed, press "-" button on the upper right corner to save..

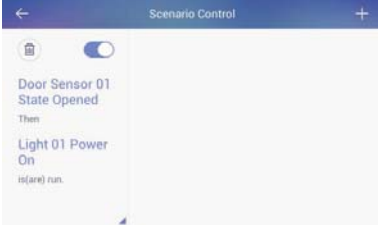

- 9) The generated scenario control is displayed.

## 6.8. Setting whether to use reservation control

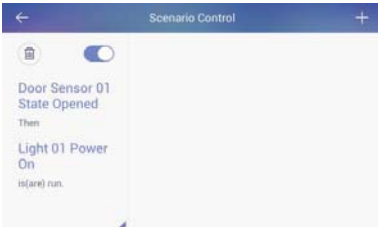

- 1) Go to the reservation control screen.
- 2) Use the toggle button ('') in the list to enable or disable the function to use.

# 7. Convenient function

## 7.1. Calculator



Arithmetic operation

You can use the arithmetic calculator function.

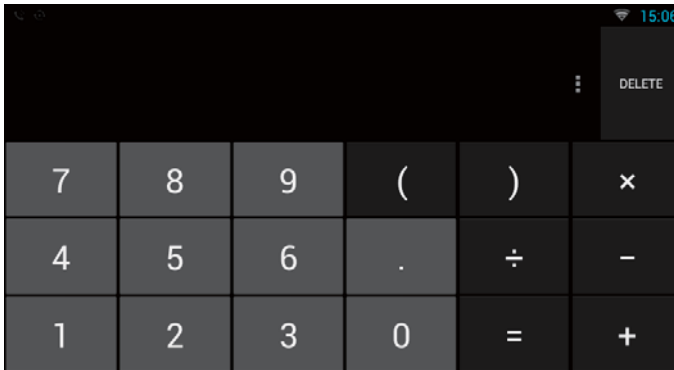

Calculator screen

# 8. Setting

## 8.1. Environment set up

You can set preferences such as user connection, language, and time.

- 1) Press the 'Set' button to display the setting screen.

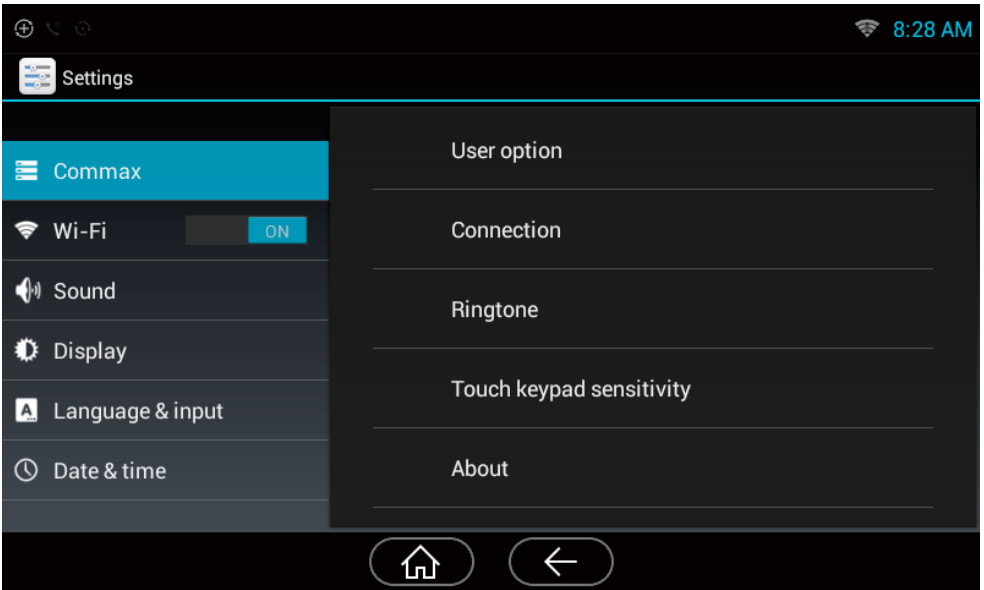

Settings Screen

## 8.2. Password change

Settings → Commax → User Options → Password

Change the password used for emergency release and exit mode setting cancellation.

- 1) Press the 'Password' button.
- 2) Enter the new password on the New Password Entry screen.
- 3) Enter the new password again.
- 4) If the entered password matches, the new password will be changed.

※ Initial password is 1234.

### 8.3. Receive a call via Smartphone

Settings → Commax → User Options → Receive a call via Smartphone

The smart device receives calls that come in Wallpad.

- 1) Check "Receive calls from smart devices" to receive calls via smart devices.
- 2) If unchecked, the smart device will not receive.

※ It can be used only when the external internet is connected.

### 8.4. Firmware update

Settings → Commax → User Options → Firmware Update

Compare the system versions and update to the latest program.

※ It can be used only when the external internet is connected.

### 8.5. Connect to COMMAX

Settings → COMMAX → Connect

You can set up environment for connection and management such as Bld./House number information, sensor, door camera format.

Do not manipulate settings other than the installer. If the correct value is not entered, connection and management will not work correctly.

#### Building / House number setting

- 1) Press the 'Building/House number' button on the menu.
- 2) Enter the appropriate building and house number press the 'Save' button.

#### Using the sensor

- 1) Click the 'Sensor setting' button in the menu.
- 2) Check the sensor of the area to be used.
- 3) Press the 'Settings' button.

#### Sensor operation test

- 1) Click the 'Test Sensor' button.
- 2) When the sensor to be tested is operated, check mark is displayed.

#### Entrance camera video format setting

- 1) Press the 'Video Format' button.
- 2) Select the video format of the front door camera. (Contact installer)



## Connection test

This is a feature for the installer. You can check if the product is connected to 'Home Server' or 'Local Server'. Click the "Test" button to confirm the access.

## Initialize user data

- 1) Click the 'Initialize User Data' button.
- 2) Press 'Reset Data' button to reset data such as 'Visitor Log', 'Visitor Image', 'Call Log', 'Emergency Log'
- 3) Data cannot be restored after initialization.

## 8.6. General setting

### Setting the ring tone

Set up → COMMAX → Bell sound

- 1) Select the location you want to set and then select the desired ring tone from the list. (Listening to the bell sound)
- 2) 'Press 'OK' button to set the selected ring tone.

### Correct Touch screen

Settings → COMMAX → Touch screen

- 1) 'Press the 'touch screen' button.
- 2) Follow the on-screen instructions and press the cross icon in order.
- 3) When the correction is completed, the completion message is displayed.

### Setting the touch keypad sensitivity

Settings → COMMAX → Keypad sensitivity

Set the touch-button sensitivity of the product.

※ During the test, " Home " key will be activated.

## 8.7. Wireless network connection

### Wi-Fi On/Off

Setting → Wi-Fi

You can turn on/off Wi-Fi.

### Wi-Fi Connection

Setting → Wi-Fi

You can search for nearby wireless networks and select the wireless network you want to connect to.

Select the Wi-Fi you want from the list of automatically discovered wireless networks, enter your password if necessary, and tap Connect. If you have secured Wi-Fi with a padlock, you'll need to enter your password before you can use it.

## **Add Wi-Fi manually**

If the Wi-Fi you want does not appear in the list, you can enter your Wi-Fi information and add it to the list. Click the "+" button at the top of the Wi-Fi list to select Add Wi-Fi networks.

Enter the network SSID and select the security type to enter the password or select the EAP method and click Connect. The information depends on the type of security you choose.

## **Disconnect Wi-Fi**

You can reset the network information that was previously connected or currently connected so that it is not automatically connected. Select the currently connected Wi-Fi and tap Do not save. The Wi-Fi connection is lost and the previous connection information is initialized.

## **8.8. Screen setting**

### **Setting the screen brightness**

Settings → Display → Brightness

- 1) Press Brightness.
- 2) The brightness window is displayed on the screen.
- 3) Use the left and right scrolls to adjust the brightness.
- 4) 'Click the 'OK' button to save the settings.

### **Setting the screen auto-off time**

Settings → Display → Power saving Mode

- 1) Press Power Saving Mode.
- 2) A list of screen time limit is displayed.
- 3) Press the desired time to save the setting. If you press 'Cancel' button, it is not set.

## **8.9. Language and key setting**

### **Change language**

Settings → Language and Keyboard → Language

You can set the language displayed on your device.

- 1) Click Language.
- 2) Select the language to set in the list.

## 8.10. Date and time setting

Settings → Date and Time

### Setting the date and time automatically

- 1) Check the date / time automatic setting.

### Setting the date and time manually

- 1) Uncheck the automatic setting of date / time.
- 2) The date and time setting items are activated.
- 3) Click Date set.
- 4) If the date setting window is displayed on the screen, set the date using + and - buttons, then press OK button.
- 5) Press the time setting to display the setting screen.
- 6) Set the time referring to the date setting.

### Specifying the time zone

- 1) Tap the time zone.
- 2) Select the time zone of your current city from the list.

### 24-hour formatting

- 1) Check or uncheck Use 24-hour format.
- 2) When checked, the time is displayed as 24 hours. When unchecked, displays in 12-hour format.

### Formatting dates

- 1) Press Select date format.
- 2) The date format selection window is displayed on the screen.
- 3) Click the format to set.

## 8.11. System information

You can check the components installed on your system and check the product firmware information.

### Checking the component version

- 1) Click Applications.
- 2) The version of the installed component is displayed.

### Checking product firmware information

The version and build number of the boot loader and kernel are displayed.

### Specifications and Characteristics

- ※ Rated input: 100~240V~, 50/60Hz (Free Voltage)
- ※ Rated power consumption: 12W (Max)
- ※ Ethernet : 100Mbps

# 9. Appendix

## 9.1. Wireless device Registration/Disconnection

### Standby power

#### Releasing the standby power switch



- 1) Press and hold the red circle button on the smart socket for about 10-13 seconds, then release it if the LED is blinking.
- 2) If the connection is successfully released, the LED will blink for about 5 seconds.

#### Registering the standby power switch

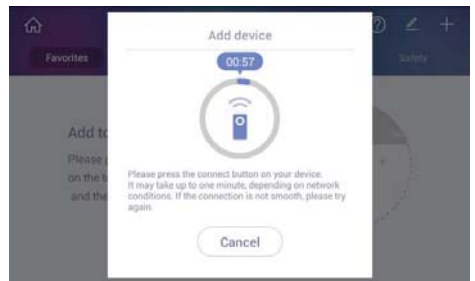

- 1) Press '+' button.

- 2) The Add Device page is provided.



- 3) Press the red circle button on the standby power switch for about 1 second. The LED will blink for about 4 seconds within 10 seconds.

- 4) When the registration is completed, "Device registered" message is displayed.

## Light switch

### Releasing light switch

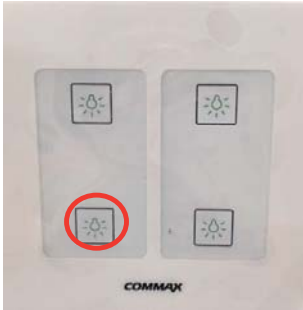

- 1) Press the red circle button on the smart switch for about 10-13 seconds, and release the beep sound. Press the red circle button once more.
- 2) When the release is completed normally, the LED will blink for 4 seconds and a "beep beep" sound will appear.

### Registering the light switch

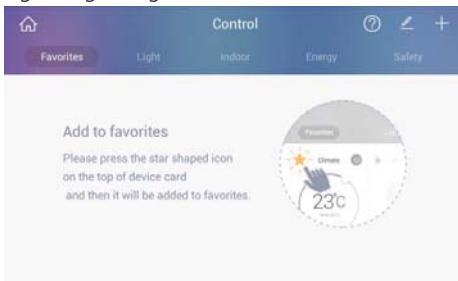

- 1) Press '+' button.

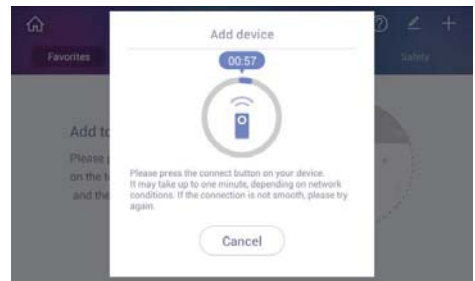
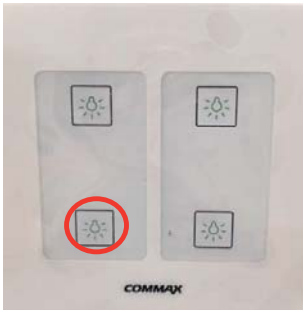

- 2) The Add Device page is provided.
- 3) Press the red circle button on the smart switch.
- 4) If the connection is successful, LED will be on for 4 seconds and "beep" sound will be heard.
- 5) If the connection fails, the LED blinks for 4 seconds and "beep" sounds.
- 6) When the registration is completed, the message "Device registered" is displayed.

## Batch off 2 lights switch

### Releasing the batch off switch



- 1) Press the red circle button on the batch off switch for about 10-13 seconds and release the beeping sound. Press the red circle button once more.
- 2) When the release is completed normally, the LED will blink for 4 seconds and a "beep beep" sound will appear.

### Registering the batch off switch

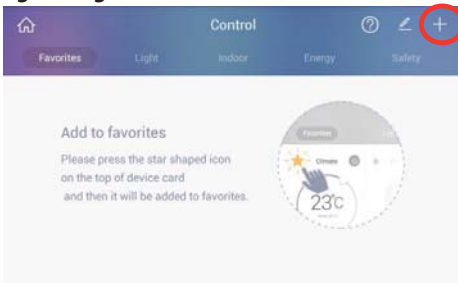

- 1) Press '+' button.

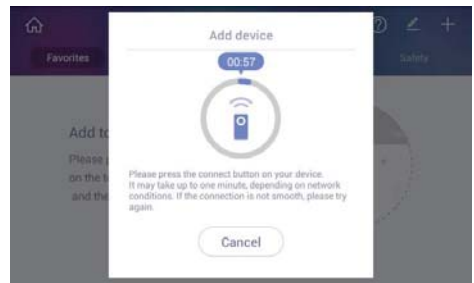

- 2) The Add Device page is provided.
- 3) Press the red circle button on the smart switch.
- 4) If the connection is successful, LED will be on for 4 seconds and "beep" sound will be heard.
- 5) If the connection fails, the LED blinks for 4 seconds and "beep" sounds.
- 6) When the registration is completed, the message "Device registered" is displayed.

## Gas valve controller

### Releasing the gas valve controller



- 1) Turn off the gas valve.
- 2) Press the "+" button for about 5 seconds to provide "P" on the gas valve screen.
- 3) Upon successful completion, the message "Device has been deleted" is displayed on the wall pad.

### Registering the gas valve controller

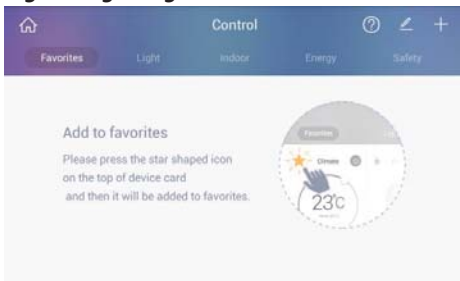

- 1) Press '+' button.

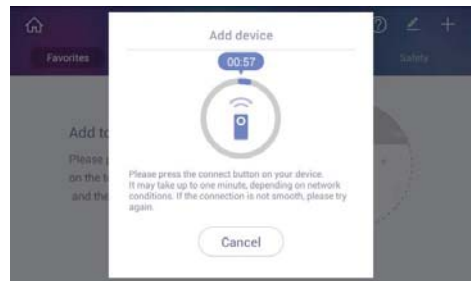

- 2) The Add Device page is provided.
- 3) Turn off the gas valve.
- 4) Press the "+" button for about 5 seconds to provide "P" on the gas valve screen
- 5) When the registration is completed, the message "Device registered" is displayed.



## Gas leak detector

### Releasing the gas leak alarm



- 1) Press the button for about 10-13 seconds (located on the top of the product)
- 2) Release the button when LED flashed.
- 3) Upon successful completion, the message "Device has been deleted" is displayed on the wall pad.

### Registering the gas leak alarm

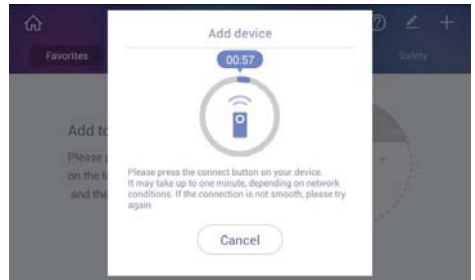
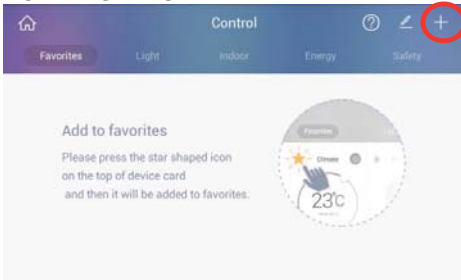

- 1) Press '+' button..



- 2) The Add Device page is provided.
- 3) Press the button for about 10-13 seconds (located on the top of the product)
- 4) Release the button when LED flashed. Press the button once more.
- 5) Upon successful completion, the message "Device has been deleted" is displayed on the wall pad.

## Magnetic door sensor

### Releasing magnetic door sensor

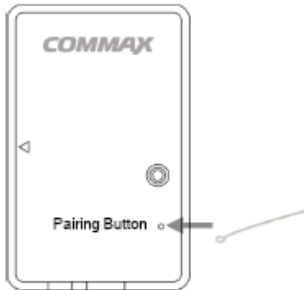

- 1) Press the button for about 10 seconds.
- 2) Release the button when LED flashed.
- 3) Upon successful completion, the message "Device has been deleted" is displayed on the wall pad.

### Registering magnetic door sensor

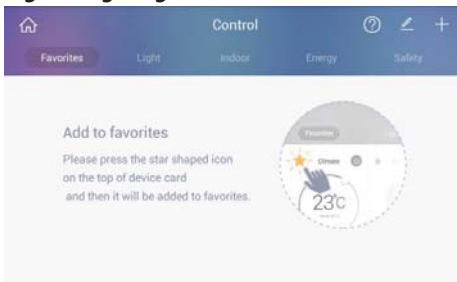

- 1) Press '+' button.

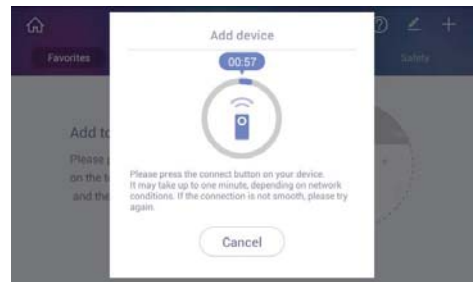
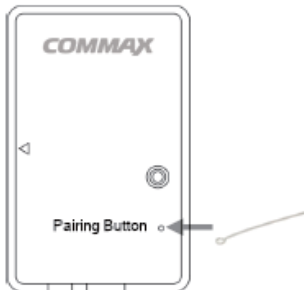

- 2) The Add Device page is provided.
- 3) Press the button.
- 4) When the registration is completed, the message "Device registered" is displayed.

## PIR sensor

### Releasing PIR sensor



- 1) Press the button for about 5 seconds.
- 2) Upon successful completion, the message "Device has been deleted" is displayed on the wall pad.

### Registering PIR sensor

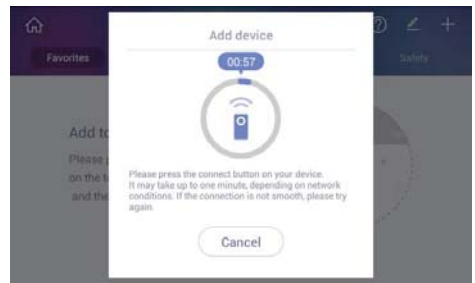
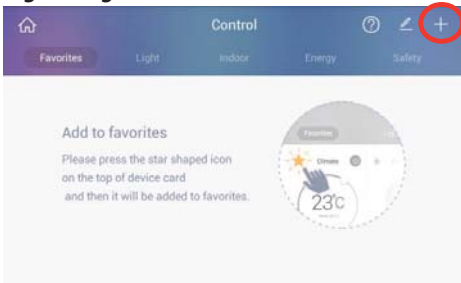

- 1) Press '+' button



- 2) The Add Device page is provided.
- 3) When the PIR battery is installed, the red LED will blink for 30 seconds and try to connect.
- 4) The red LED changes to green LED and turns OFF.
- 3) When the registration is completed, the message "Device registered" is displayed.

## 9.2. Installation

### ▷ Monitor installation

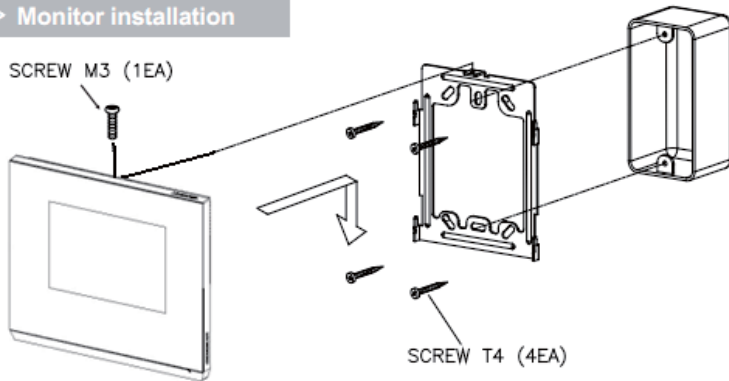

#### \* Note

- Avoid installing the product in the area of direct sunlight.
- The position of the unit's body should fit the standard height range (Recommended height range is 1450 ~ 1500mm.)
- Avoid installing the product exposed to gas exposure, magnetic force, in humid temperatures, as it may damage the condition and performance of the product.

### ▷ Camera Installation (at DRC-4L)

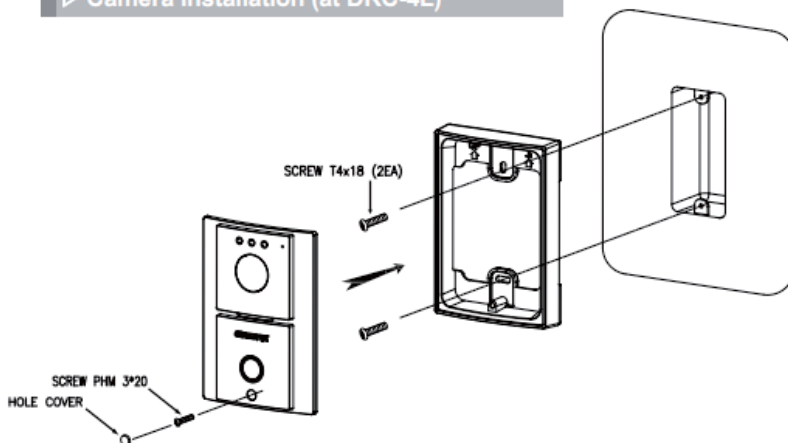

#### \* Note

- Do not install a door camera in the area exposed to direct sunlight or backlight.
- Please keep the lens clean for the clearest image reflection.

### 9.3. Wiring Diagram and Components

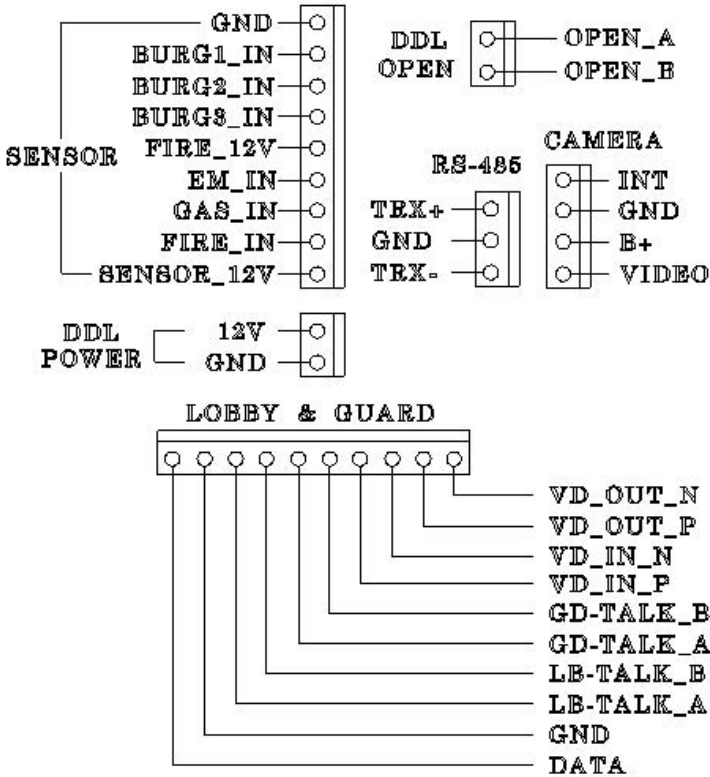

#### Precautions when wiring

- 1) When installing in the area where the high-voltage line passes around, use the coaxial wire to wire the metal pipe.
- 2) It may be short-circuited if internal wires are exposed due to scratches on the wire sheath, which may cause malfunction.
- 3) Turn off the monitor's power switch when connecting the monitor to the camera.
- 4) The wiring between camera and monitor is polarity.
- 5) When connecting various sensors, be careful about power and polarity.

# Components



CAV-70MGX+



Wall bracket  
for Monitor (1EA)



Manual (1EA)

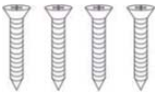

(T)4x18mm (4EA)

Wall bracket Mounting Screw



(M)3x6mm (1EA)

Monitor fixing Screw

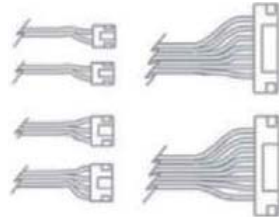

2P(2EA) / 9P(1EA)

3P(1EA) / 10P(1EA)

4P(1EA) Connectors

# 10. Specification

Spec. / Model	CAV-70MGX+
Wiring Q'ty	Common Area : 8EA / Individual Door : 4EA / RS-485 : 3EA (Network Boiler) Sensor : 6EA / DDL Open : 2EA / DDL Power : 2EA
Power	AC 100 ~ 240V , 50~60Hz
Power Consumption	Standby : 5W / Max. 15W
Communication Method	Hands Free
Sound	Individual Door : Electronic Chime with 3 Tones (For 2 consecutive times) Common Area : Electronic Bell
Communication Range	Individual Door : 28m with $\Phi$ 0.5 Cable
Operation Temperature	0 ~ +40°C (32°F ~ 104°F)
Outside Size	181(W) X 245(H) X 32(D) mm

## WI-FI (IEEE 892.11 b/g/n)

Items	Specification
Receiver sensitivity	-76dBm @ 802.11b 11Mbps -65dBm @ 802.11g 54Mbps -64dBm @ 802.11n MCS7
Transmit power	17dBm @ 802.11b 1~11Mbps 15dBm @ 802.11g 54Mbps 14dBm @ 802.11n MCS7
Frequency bands	2412MHz ~ 2472MHz
Supply voltage Range	5V or 3V

## ZigBee

Items	Specification	Remark
Receiver sensitivity	-95dBm @ 1% PER	802.15.4 Section 6.5.3.3
Transmit power	+2.5dBm	
Z-Wave data rates	250kbps	
Frequency bands	2400MHz ~ 2485MHz	
Supply voltage range	2.0V to 3.6V	
RF Range	10~75m range	Less than 75m/1mW(0dBm)

# COMMAX

**COMMAX Co.,Ltd.**

513-11, Sangdaewon-dong, Jungwon-gu, Seongnam-si, Gyeonggi-do, Korea  
Int'l Business Dept. Tel. : +82-31-7393-540~550 Fax. : +82-31-745-2133  
Web site : [www.commax.com](http://www.commax.com)

*PM0270MGX+10*

*Printed In Korea / 2016.03.104*